



Specializing in Cafeteria Serving Lines

G.A. SYSTEMS, Inc.

Stainless Steel Trough



Project: _____
 Item #: _____
 Model #: _____

Stainless Steel Trough with trivet is a great addition to any central kitchen. Empty cans of fruit into the trough to drain fruit juice before packaging individual servings. Clean up is a breeze with the 1-1/4" ball valve located at the bottom of well to drain juices.

SPECIFICATIONS

Top frame is fabricated of 18 gauge 1-1/2" stainless steel tubing. Upright legs are fabricated of 1-5/8" 18 gauge stainless steel. Leg supports are fabricated of 1" 18 gauge stainless steel. Food well is fabricated of 18 gauge stainless steel with roll formed interior corners.

Removable stainless steel trivet is fabricated of 18 gauge stainless steel with 1/4" holes (larger size holes available upon request). 1-1/4" ball valve at bottom of well for drainage.

Plate type 4" swivel non-marking casters with brakes all NSF approved.

DIMENSIONS

MODEL	A	B	C
C0302	38"	28"	36-1/8"

OPTIONS

- Drain on side- Model #C0357

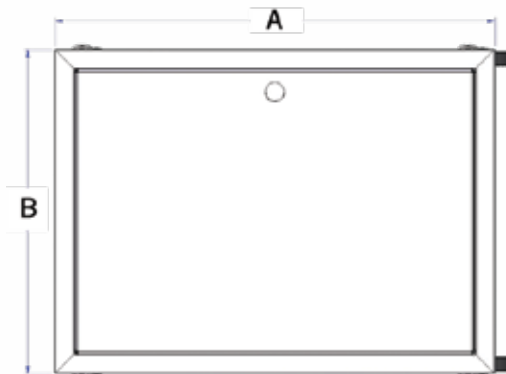
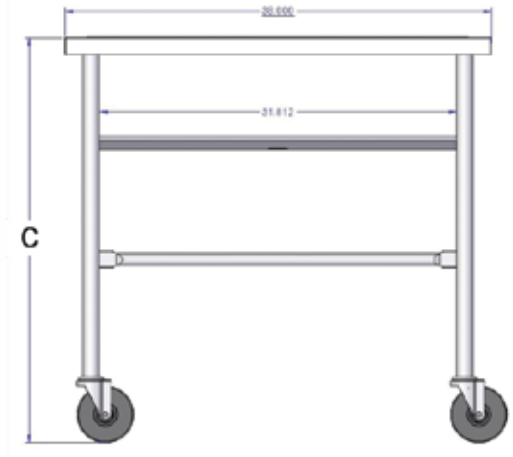

Rev 03/2018